



BRUSHED SMOOTH OR CEDAR TEXTURE PRIMED NICKEL GAP SIDING

LOUISIANA-PACIFIC CORPORATION PERIODICALLY UPDATES AND REVISES ITS PRODUCT INFORMATION AND APPLICATION INSTRUCTIONS. WARRANTY REMEDIES ARE NOT AVAILABLE IF THESE APPLICATION INSTRUCTIONS ARE NOT FOLLOWED. THE INFORMATION IN THIS DOCUMENT IS SUBJECT TO CHANGE WITHOUT NOTICE.

FIND ALL LP® SMARTSIDE® PRODUCT LITERATURE AT LPCORP.COM/SMARTSIDE

LP® SmartSide® Trim & Siding is covered under the LP® SmartSide® Prorated 50-Year Limited Warranty. Refer to the warranty, which is available online, for complete terms and conditions. Product must be transported, stored, handled, installed, finished, and maintained in accordance with all published application, finishing, maintenance instructions, technical notes, and bulletins (collectively, "Instructions") in effect at the time of installation.

Failure to follow such Instructions will make the limited warranty inapplicable as to the products affected by such failure. No modification or exception to these Instructions and no non-published recommendations are valid unless issued in writing on a project-specific basis by LP's Director of Technology prior to application. Always check and comply with local building codes. Even where these instructions approve installation over certain substrates or incorporate requirements of building codes, LP's liability for the performance of the product is limited as expressly provided in the Limited Warranty.

⚠ WARNING: Drilling, sawing, sanding or machining wood products can expose you to wood dust, a substance known to the State of California to cause cancer. Avoid inhaling wood dust or use a dust mask or other safeguards for personal protection. For more information go to P65Warnings.ca.gov/wood-dust.

PRODUCT LEGEND

- A LP® SmartSide® Lap Siding
- B LP® SmartSide® Panel Siding
- C LP® SmartSide® Vertical Siding
- D LP® SmartSide® Cedar Shake
- E LP® SmartSide® Trim & Fascia
- F LP® SmartSide® Soffit
- G LP® SmartSide® ExpertFinish® Lap Joint Siding
- H LP® SmartSide® Accessories
- I LP® SmartSide® Nickel Gap Siding



GENERAL INFORMATION

HANDLING

- Handle siding with care during storage, temporary placement, and application.
 - Additional care is required to ensure shiplap edges are not damaged.

STORAGE

- Store siding:
 - Under a roof or waterproof covering (like unit cover/bonnet).
 - Off the ground, on a flat-drained surface using supports that provide a min. 1-1/2" (38 mm) clearance from surface.
 - This includes when staging siding around jobsite during installtion.
- LP is not responsible for damage due to improper handling and storage of the siding.



BEFORE YOU BEGIN

- At the time of manufacture, siding meets or exceeds the performance standards set forth in ICC-ES AC321 and has achieved recognition under PR-N124 and HUD-MR-1318d. For copies of product approvals go online at <https://lpcorp.com/product-literature> or call LP Customer Support at 888-820-0325.
- Where Nickel Gap siding butts window trim, door casings, etc. or at butt joints, leave a 3/16 inch (5 mm) gap and seal.
 - Larger gap is required when siding is adjacent to stucco, brick, cultured stone, mortar, etc. (Figure 3b)

GENERAL INFORMATION (CONT'D.)

- Min. 6 inch (152 mm) clearance must be maintained between siding and finish grade (ground cover). *[Min. 200 mm (8 inch) clearance must be maintained between cladding and finish ground when installing cladding in Canada in accordance with NBC, Section 9.27.2.4.(1) or local building code requirements.]* (Figure 6a, 6b, 6c)
- Siding applied adjacent to surfaces such as porches, patios, balconies, or walking surfaces (including porch columns) must have a clearance of at least 1 inch (25 mm) above horizontal surface.
 - Clearance may be reduced to 3/8 inch (10 mm) for:
 - Porches, patios, balconies, or walking surfaces that slope away from the structure or the surface provides gaps that allow water to flow through so that it cannot accumulate, and is covered by a roof, not an eave or overhang; or
 - Porch columns with walking surfaces that slope away from the structure or the surface provides gaps that allow water to flow through so that it cannot accumulate.
- All wood substrate directly exposed to the weather must be sealed to prevent moisture intrusion and water build up.
 - Seal ALL exposed cuts of siding. Field spray applied coatings on cuts are not recommended.
 - Sealing can be accomplished by applying a paint or sealant according to the manufacturer's requirements.
- See **Alternate Fastening Options** starting on page 7 for Nickel Gap siding installed vertically, page 8 for attaching Nickel Gap siding to SIP or wood structural panel sheathing, steel studs, or Insulated Concrete Form (ICF) assemblies.

TRIM

- Use a min. 440 Series trim so the siding does not extend beyond the face of the trim.
 - If trim is installed over siding, 190 Series trim may be used.
- Lap siding is not designed to be used as trim.
- See page 9 for PREFERRED and ALTERNATE details for Outside and Inside Corner Trim. (Figure 9d, 9e, 9f, 9g)

FLASHING

- All openings must be properly sealed or flashed in a manner that prevents moisture intrusion or buildup.
- Flashing shall be metal or another durable material that will last for not less than 50 years.
- Install step flashing at roof-to-wall intersections with a min. 4 inch (102 mm) upper leg. (Figure 2a, 2b)
- All other flashing must have a min. 4 inch (102 mm) upper leg.
 - Add 4 inch (102 mm) wide adhesive flashing when upper leg is less than 4 inches (102 mm).
- Properly integrate flashing with WRB. Use WRB or flashing tape to maintain counterflashing principle.
- LP manufactures a custom pan flashing profile intended to be used with Nickel Gap lap siding. Refer to pages 5 and 6 for butt-joint flashing options and installation guidelines.

ROOF TO WALL INTERSECTION

- Maintain 1 inch (25 mm) clearance between siding and roofing, or trim and roofing. *[Min. 50 mm (2 inch) clearance at intersection with roof line must be maintained between roof surface and cladding when installing cladding in Canada in accordance with the NBC, Section 9.27.2.4.(2) or local building code requirements.]*

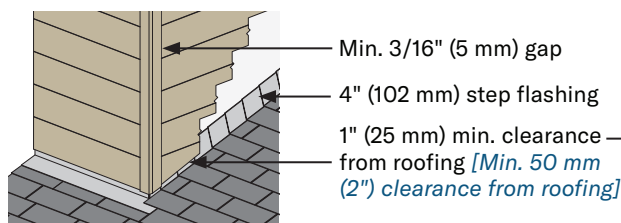

Roofing Option - Siding
Figure 2a

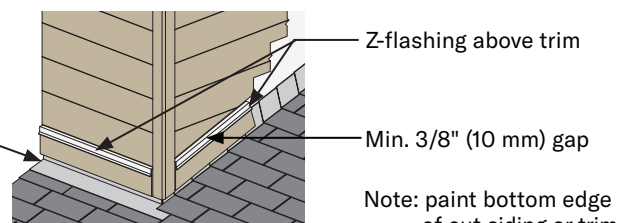

Roofing Option - Trim
Figure 2b

Note: paint bottom edge of cut siding or trim

KICK-OUT FLASHING

- Install kick-out flashing at roof eave-to-wall intersections to direct water into gutter.
- **DO NOT extend siding or trim into kick-out flashing or gutter.**
- Maintain 1 inch (25 mm) clearance between the end of the gutter and the adjoining wall to allow for proper maintenance of the siding.

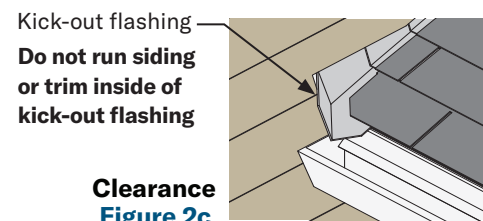

Clearance
Figure 2c

MOISTURE

- Moisture and vapor control are critical elements of proper housing design.
 - Check your local building code for requirements for handling moisture and water vapor in your area.
 - Do not apply engineered wood siding to a structure having excessive moisture conditions such as drying concrete, plaster or wet blown cellulose insulation.
 - If such conditions exist, building should be well ventilated to allow to dry prior to siding application.
 - When using wet blown cellulose insulation it must not be in direct contact with the siding, and it must be allowed to dry a min. of 24 hours or longer if specified by the insulation manufacturer.
- Siding must not be installed on green or crooked studs.
- Green studs must be allowed to equilibrate to ambient moisture conditions before siding is installed, and siding must be shimmed to maintain flatness if studs are crooked.
- Do not apply siding over rain-soaked or buckled sheathing.

WATER-RESISTIVE BARRIER (WRB)

- A properly installed WRB is required behind siding, unless exempt by building code.
- LP assumes no liability for water penetration or any other issues associated with the WRB.

OVERLAP, CLEARANCE & NAIL PLACEMENT

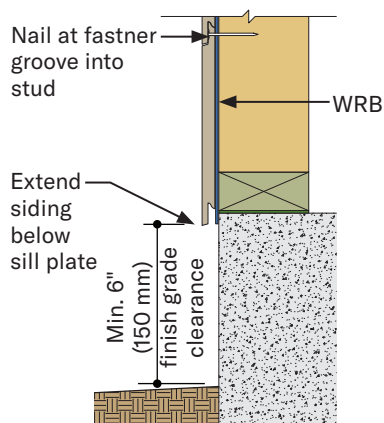

Siding - Direct to Stud Attachment
Figure 3a

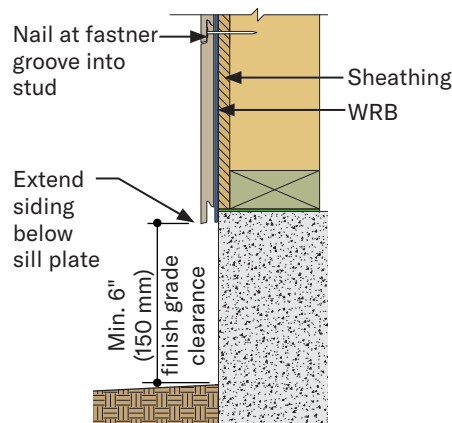

Siding - Direct to Stud w/WSP Attachment
Figure 3b

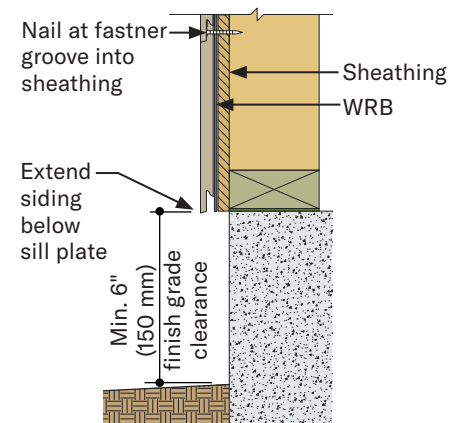

Siding - WSP Sheathing Attachment
Figure 3c

TRIM OR SIDING ADJACENT TO STUCCO/MASONRY

- Do not install trim or siding horizontally to create ledge or window sill. (Figure 3d)
- Where siding is installed directly adjacent to stucco, brick, cultured stone, mortar, etc. (Figure 3e, 3f)
 - Leave a min. 3/8 inch (10 mm) gap and caulk, backer rod recommended.
- Where siding is installed adjacent to stucco, brick, cultured stone, mortar, etc. with metal trim system. (Figure 3g)
 - Leave a min. 3/16 inch (10 mm) gap and caulk, backer rod recommended.

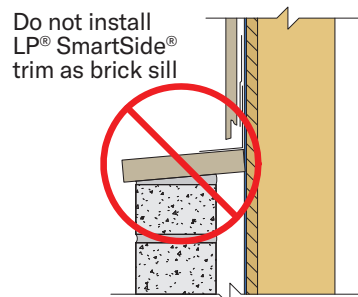

Section View
Figure 3d

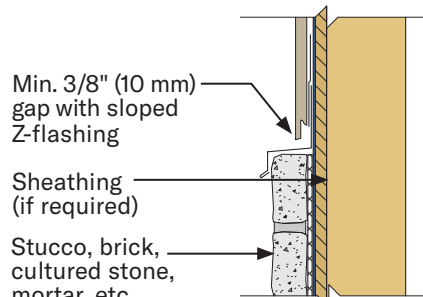

Section View
Figure 3e

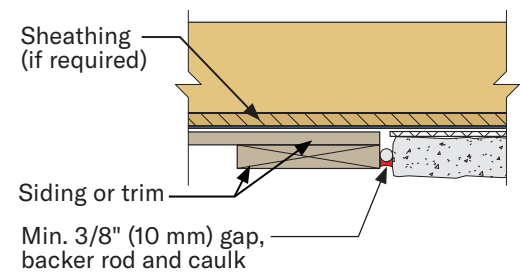

Plan View
Figure 3f

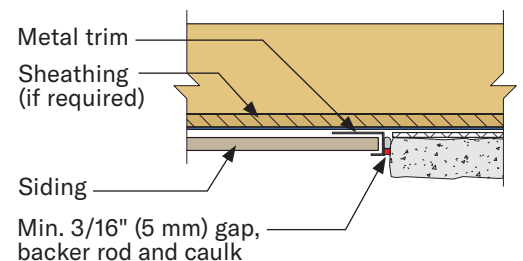

Plan View
Figure 3g

FASTENING INSTRUCTIONS

STUD SPACING OPTIONS

- Siding may be attached **direct to studs** spaced max. 24 inches (610 mm) o.c.
- Siding may be attached **directly to a min. 7/16 Category wood structural panel (WSP) sheathing** with studs spaced a max. 24 inches (610 mm) o.c. (Figure 8c, 8d)

INSTALLATION

- Provide separation of Nickel Gap siding from CMU or poured concrete foundation. (Figures 3a, 3b, 3c)
 - Separation should be achieved by ensuring WRB is placed behind siding.
 - A starter strip is not required.
- Install siding blind-nailed, place nail in fastener groove. (Figure 4a)
 - Stack successive courses, stagger butt joints a min. of 16 inches (406 mm).
 - The following tools may be used to assist in obtaining desired gap when stacking pieces:
 - Pull bar - typically used to install wood flooring, can be used to pull siding together to achieve desired horizontal gap. (Figure 4b)
 - Blocking. Create blocking by cutting a section of Nickel Gap siding. Remove top nailing flange to create a flat surface. Rest blocking on top flange and tap siding into place. (Figure 4c)
 - Desired gap can range between 1/16 inch (2 mm) and 1/8 inch (3 mm). Use a 0.092 inch or 0.113 inch diameter nail to verify desired gap is achieved.
 - Do not damage** nailing flange of lower piece when using pull bar or blocking, so it does not interfere with the ability for siding to stack.
- Nail from the center of the siding toward the ends, or from one end to the other end. NEVER nail from the ends of the siding toward the middle.
- Use a min. 0.092 inch shank diameter, hot-dip galvanized nail (ASTM A153, Class D) or equivalent; capable of preventing rust, stain and deterioration under normal outdoor environmental conditions for a period of no less than 50 years. Penetrate studs or combination of WSP sheathing and studs a min. of 1-1/2 inches (38 mm).
 - A larger 0.113 inch shank diameter nail may be required depending on the wind pressure, wind speed and wind exposure category limitations in PR-N124. Penetrate studs or combination of WSP sheathing and studs a min. of 2 inches (51 mm).
- Butt joints should be staggered over successive courses.
- Top flange must be ripped at top of wall where siding meets soffit or freize board. (Figure 4d)
- Do not overdrive nails. (Figure 4e)
 - Nail head should seat snug in fastener groove, but not countersunk which is considered overdriven.
 - Blind nails:** only correction required would be re-nailing when countersunk more than 1/8 inch. (Figure 4f)
 - Face nails:** will occur immediately below window sills, soffit, freize boards, and horizontal trim. Corrections are detailed in Figure 4g.
- Painting all exposed nail heads is recommended.

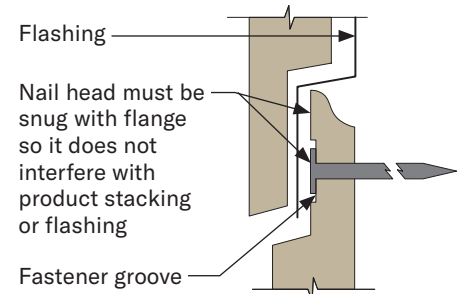
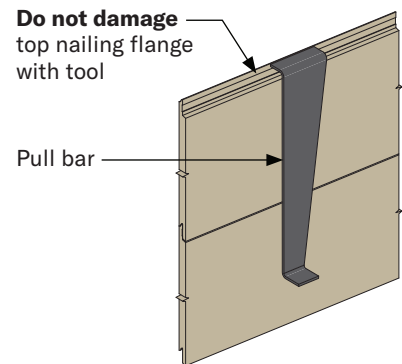
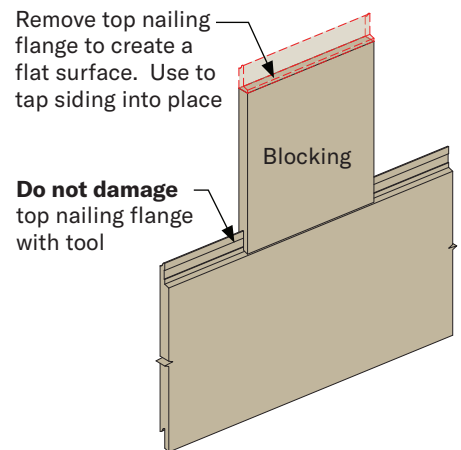

Figure 4a



Pull Bar Option
Figure 4b



Blocking Option
Figure 4c

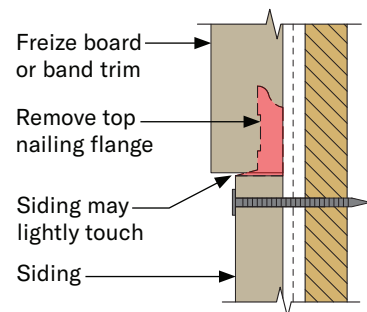
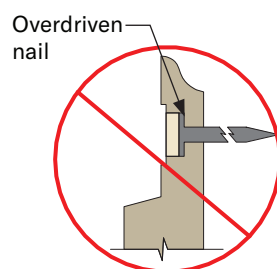
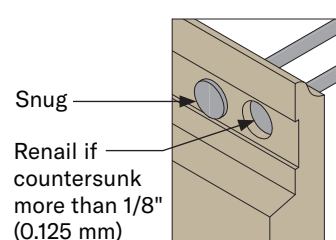

Figure 4d



INCORRECT
Figure 4e



BLIND NAILED
CONDITION
Figure 4f

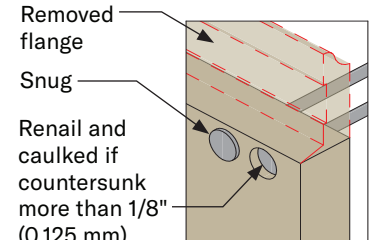

FACE NAILED
CONDITION
Figure 4g

FIRE-RATING

FIRE-RATED WALL ASSEMBLY

- LP SmartSide Nickel Gap lap siding may be installed over the exterior portion of a 1-hour fire-resistive exterior wall assembly, including assemblies using gypsum wallboard listed in the Gypsum Association Fire Resistance Design Manual.
- For information on fire-rated wall assemblies: <https://lpcorp.com/products/panels-sheathing/fire-rated-osb-sheathing/assemblies>

BUTT JOINTS

- Provide a min. 3/16 inch (5 mm) gap at butt joint. (Figure 5a)
 - Use spacing tool like SIMPLESIDER® siding gauge (Figure 5b) or rafter square (Figure 5c) to achieve proper gapping.
 - Rafter square thickness varies between manufacturers, confirm min. 3/16 inch (5 mm) thickness provided before using as spacing tool.
 - Gapping will allow for linear expansion of siding.
 - Caulk is not required.

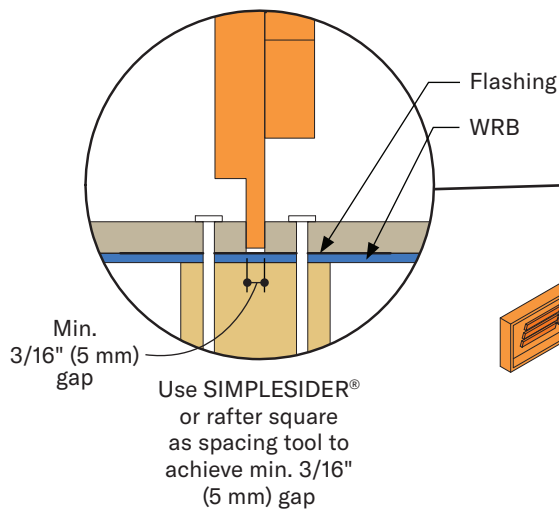
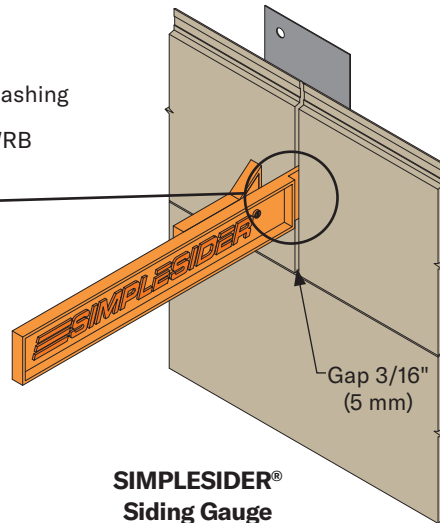
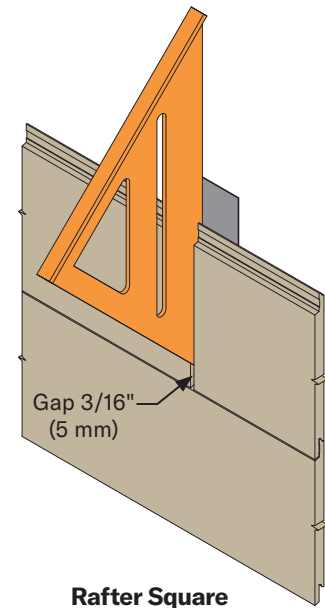

Figure 5a



**SIMPLESIDER®
Siding Gauge
Figure 5b**



**Rafter Square
Figure 5c**

- Flashing butt joints can be accomplished by using one of three options:

1. **LP SmartFlash metal flashing** is specifically manufactured to integrate with Nickel Gap siding. (Figure 5d)
 - A portion of the flange located on back of siding has been removed to receive flashing. (Figure 5e)

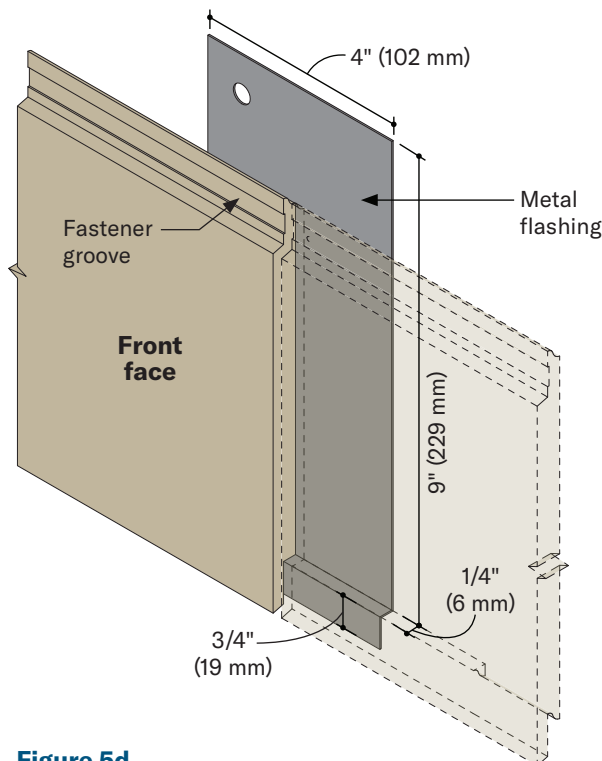

Figure 5d

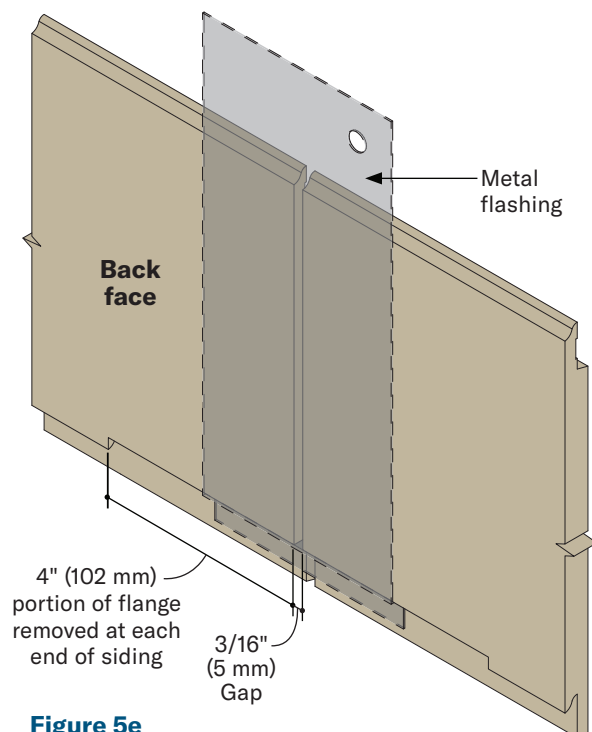
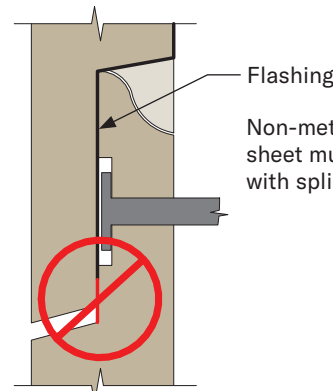

Figure 5e

BUTT JOINTS (CONT'D.)

2. Field fabricated metal flashing.

- Ensure nail head is snug to the face of the fastener groove so it does not interfere with installing the flashing.
- Ensure flashing does not restrict vertical movement at the nailing flange and does not interfere with the siding to properly stack or lay flat.
- Vertical leg of flashing is long enough to cover nail head and does not extend to the bottom of the nailing flange. (Figure 6a)



Flashing Length
Figure 6a

3. Non-metal flexible flashing sheet.

- Non-metal flexible **flashing sheets** must conform to nailing flange, shall not prevent siding from properly stacking, laying flat or provide proper drainage. (Figure 6b)
- May use non-metal flexible flashing sheet such as Bear Skin flashing sheets.

Non-metal flashing sheet must conform with spline profile

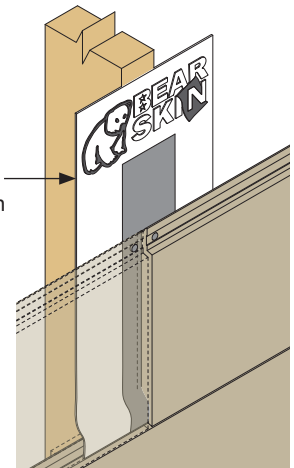

Figure 6b

FASTENING OPTIONS OVER FOAM PLASTIC SHEATHING (RIGID FOAM INSULATION)

- Nickel Gap siding may be installed directly over foam sheathing.

FOAM PLASTIC SHEATHING ≤ 1 INCH (25 MM)

- Increase nail length to ensure the required min. penetration into studs, or combination of studs and WSP sheathing (Figure 6c), or WSP sheathing only attachment. (Figure 6d)

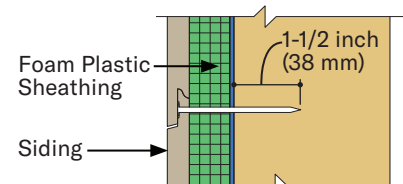

Figure 6c

FOAM PLASTIC SHEATHING > 1 INCH (25 MM)

- Siding attachment: Refer to IRC Chapter 7, Wall Covering for prescriptive siding attachments over foam sheathing up to 4 inches (102 mm) thick, direct to wood or steel studs for support of siding weight only.

Does NOT include wind loads.

- Refer to Table 703.15.1 for min. fastening requirements over foam sheathing to wood studs.
- Refer to Table 703.16.1 for min. fastening requirements over foam sheathing to steel studs.
- Fastener placement:
 - Nail spacing depends on siding attachment method; Direct to Stud or wood structural panel (WSP) sheathing attachment, and
 - Wind load limitations which can be found in PR-N124 or ESR-1301.
- LP assumes no liability for loss or damage associated with fastening requirements of the applicable code.

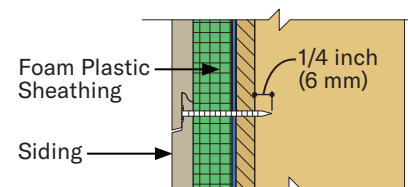

Figure 6d

ADDITIONAL FASTENING OPTIONS

EXTERIOR GYPSUM SHEATHING

- Siding may be installed over exterior gypsum sheathing, according to the following:
 - Adequate bracing of the wall is provided in accordance with the local building code.
 - Nail length must be increased to ensure the required min. penetration into wood studs, or combination of WSP sheathing and wood studs.

EXISTING WOOD SIDING OR WOOD COMPOSITE SIDING

- Siding may be installed over existing wood or wood composite siding, if the existing siding does not affect the ability to correctly install siding.
 - A properly installed WRB is required between the existing siding and the new siding.
 - A uniform surface behind siding is required to avoid contouring of siding.
 - Do not install over existing siding that is not flat or uniform, for example, over lap or clapboard siding.
 - Min. nail penetration and max. stud spacing must not be compromised.
 - Ensure wall assembly meets structural requirements specified in building code and by local code authority.
 - Repair any areas of the existing siding that are not structurally sound, not installed correctly, or exhibit signs of decay.

FINISHING INSTRUCTIONS

- Seal gaps with a high-quality, non-hardening, paintable sealant meeting ASTM C920, minimum Class 25.
 - Follow sealant manufacturer's instructions for application.
- Paint all exposed surfaces, including all drip edges or where water will hang. For best results, use a high-quality 100% acrylic exterior paint specially formulated for use on wood and engineered wood substrates; oil paint is acceptable.
 - DO NOT USE stain or vinyl-based paint.
 - Apply paint as soon as possible and within 180 days.
 - Follow paint manufacturer's instructions for application.
 - Follow LP's Care & Maintenance Instructions.

FINISHING INSTRUCTIONS

CEDAR TEXTURE Nickel Gap Siding:

- For best results use semi-gloss finish.

BRUSHED SMOOTH Lap Siding:

- Either flat, satin or semi-gloss coatings can be applied to brushed smooth finish lap siding.
 - Each offers different appearance & maintenance benefits.

ALTERNATE FASTENING OPTIONS

NICKEL GAP SIDING INSTALLED VERTICALLY

- Siding must be installed in a sheathing only attachment method over min. 7/16 Category WSP sheathing with an APA Trademark that contains the consensus Standard DOC PS 2.
 - Exception: can be installed over LP® FlameBlock® Fire-Rated OSB Sheathing.
- Remove bottom nailing flange when installing siding next to trim. (Figure 7a)
 - Removing top nailing flange is not required when installing next to trim.
 - Do not nail through top flange.
- The following tools may be used to assist in obtaining desired gap when stacking pieces:
 - Pull bar - typically used to install wood flooring, can be used to pull siding together to achieve desired vertical gap. (Figure 7b)
 - Blocking. Create blocking by cutting a section of Nickel Gap siding. Remove top nailing flange to create a flat surface. Rest blocking on top flange and tap siding into place. (Figure 7c)
 - **Do not damage** top nailing flange when using these tools.
- Siding nail requirements:
 - Use a min. 0.092 inch diameter **ring shank**, hot-dip galvanized nail (ASTM A153, Class D) or equivalent.
 - Nail shall be long enough to fully penetrate WSP sheathing by at least 1/4 inch (6 mm). Ensure that the ring shanks of the nail fully engage the WSP sheathing.
 - **Caution:** nail length should be chosen to reduce possible damage to wiring or utilities in wall.
 - Place nails max. 24 inches (610 mm) o.c. along fastener groove. (Figure 7d)
- Due to expected plate shrinkage, each vertical application of Nickel Gap is not to span beyond one floor to ceiling distance, or one floor to top of gable distance. (Figures 8a)
 - Exception: residing existing structures.

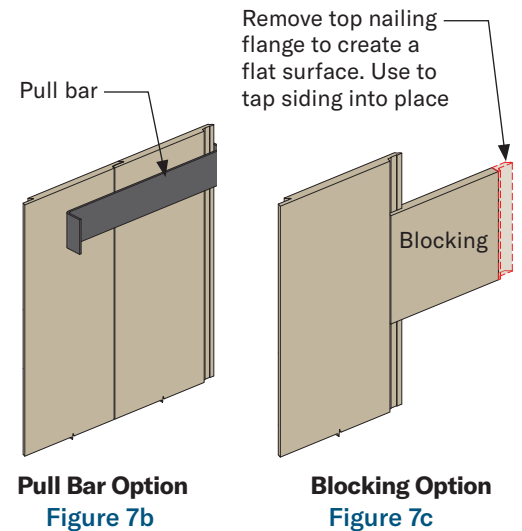

Pull Bar Option
Figure 7b

Blocking Option
Figure 7c

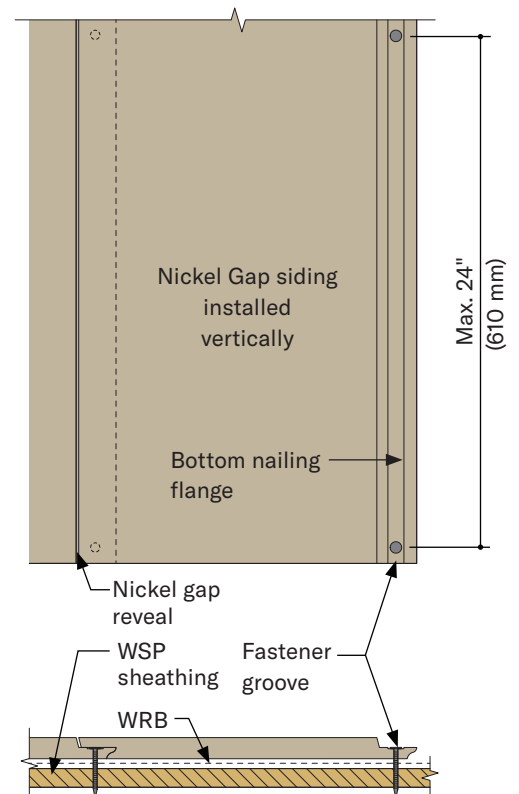

Figure 7d

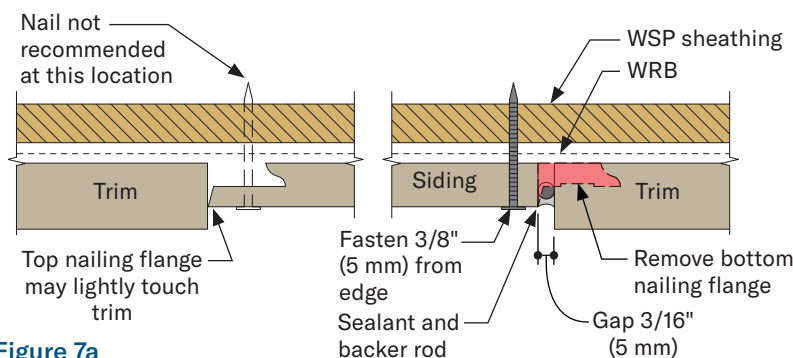

Figure 7a

NICKEL GAP SIDING INSTALLED VERTICALLY (CONT'D.)

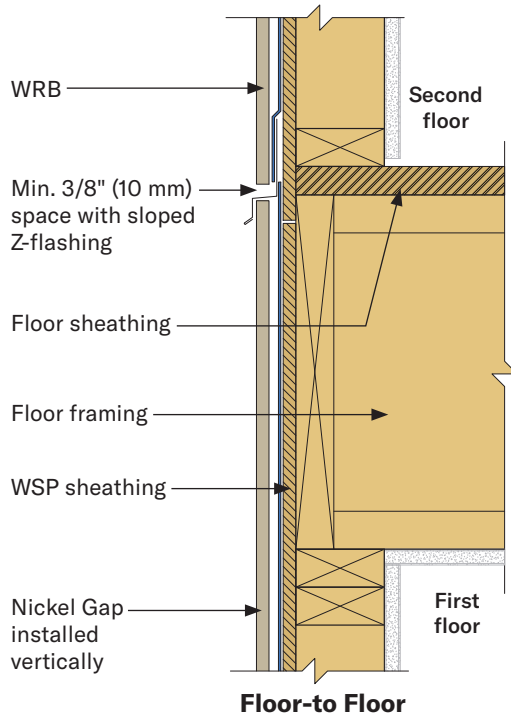

Figure 8a

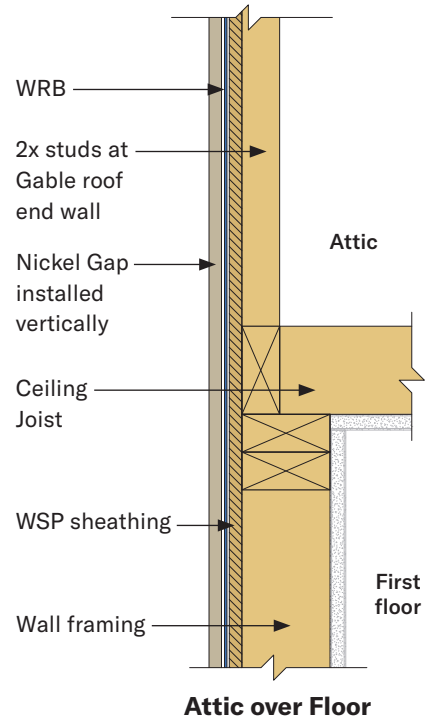
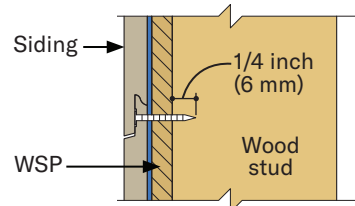

Figure 8b

NICKEL GAP SIDING INSTALLED HORIZONTALLY TO WOOD STRUCTURAL PANEL (WSP) SHEATHING OR SIP ASSEMBLIES

- WSP wall sheathing must be a min. 7/16 Category with APA Trademark that contains the consensus Standard DOC PS 2.
- Siding may be nailed to SIP or WSP sheathing with:
 - Min. 0.092 inch diameter **ring shank**, hot-dip galvanized nail (ASTM A153, Class D) or equivalent.
 - Nail length must be long enough to fully penetrate sheathing by at least 1/4 inch (6 mm). (Figures 8c, 8d)
 - Ensure that the ring shanks of the nail fully engage the wood structural panel sheathing.
 - Space fasteners depending on the wind pressure, wind speed and wind exposure category limitations in PR-N124, Table 4a or 4b; or ESR-1301, Table 4a or 4b.



Siding nailed to WSP Sheathing
Figure 8c

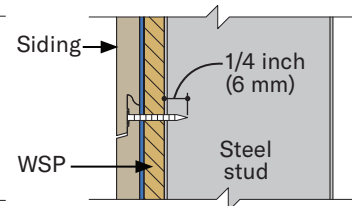

Siding nailed to WSP Sheathing
Figure 8d

STEEL STUD FRAMING ASSEMBLIES

- Siding must be fastened with:
 - Min. #8 stainless steel or equivalent, self-drilling tapered head screw.
 - Min. of 5 threads beyond the combined thickness of the siding and steel stud framing. (Figures 8e, 8f)
- Min. steel stud thickness of 0.032 inch or 20 gauge.
- Min. withdrawal value of steel stud must be 50 lbs. (23 kg).
 - Refer to steel stud manufacturer's evaluation report.

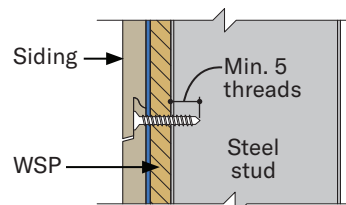

Siding screwed to Steel Stud
Figure 8e

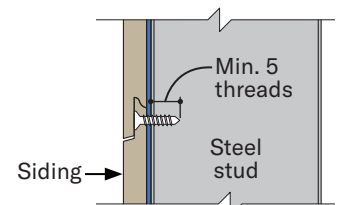

Siding screwed to Steel Stud
Figure 8f

INSULATED CONCRETE FORMS (ICF) ASSEMBLIES

- Siding must be fastened with:
 - Min. #8 stainless steel or equivalent, self-drilling tapered head screw.
 - Min. penetration of 3/8 inch (10 mm) beyond the thickness of the nailing flange.
- Larger screws may be required by ICF Manufacturer based on the following min. withdrawal requirements.
 - Min. withdrawal value of ICF nailing flange must be 50 lbs. (23 kg) with max. 12 inches (305 mm) o.c. spacing.
 - Min. withdrawal value of ICF nailing flange must be 31 lbs. (14 kg) with max. 6 inches (152 mm) o.c. spacing.

GENERAL INFORMATION

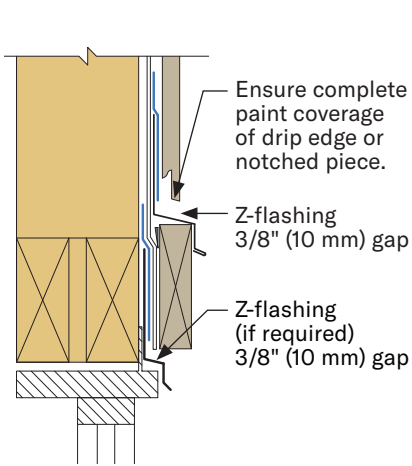

FLASHING OVER DOOR & WINDOW OPENINGS

Figure 9a

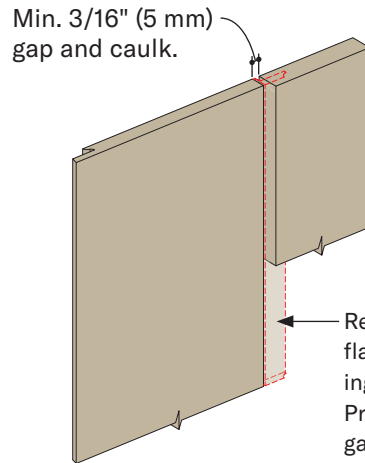

SIDING INSTALLED VERTICALLY

Figure 9b

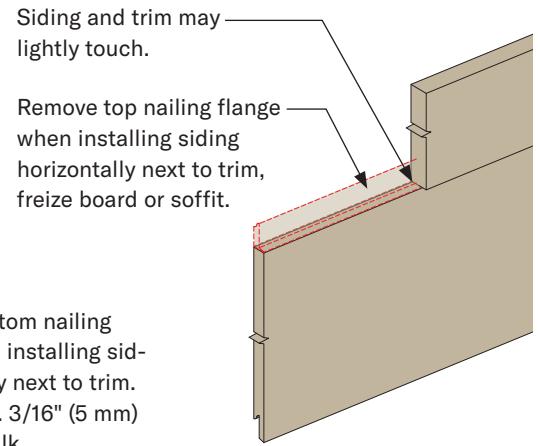

SIDING INSTALLED HORIZONTALLY

Figure 9c

Min. 3/16" (5 mm) gap and caulk when bottom nailing flange has been removed at similar conditions. (Figure 9b)

Min. 3/16" (5 mm) gap and caulk when siding has been notched and top nailing flange has been removed at similar conditions.

Fasten 3/8" (10 mm) from edge of siding at this location

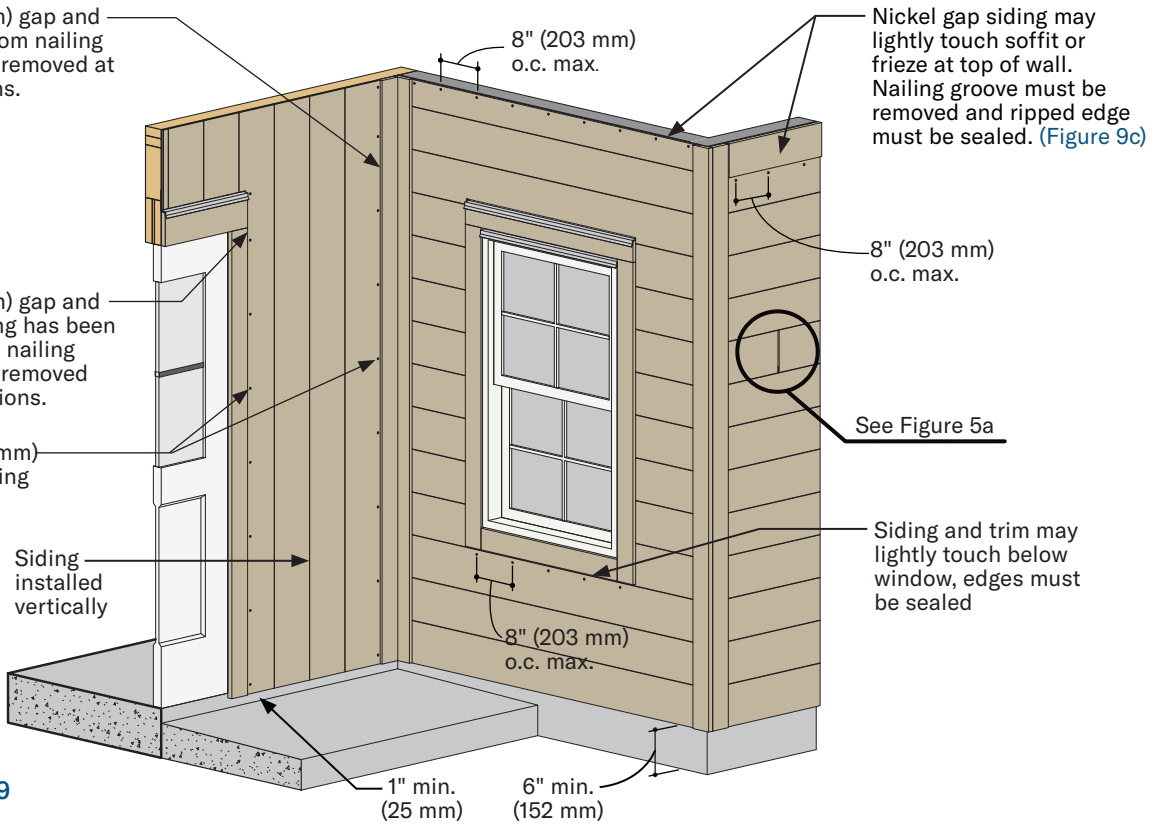
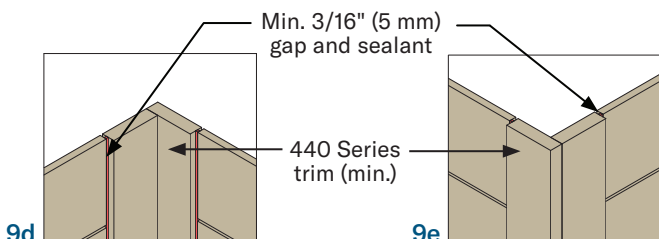
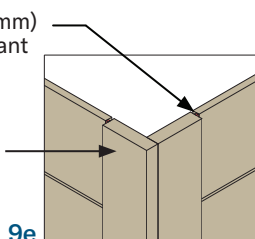

Figure 9



9d INSIDE CORNER PREFERRED



9e OUTSIDE CORNER PREFERRED

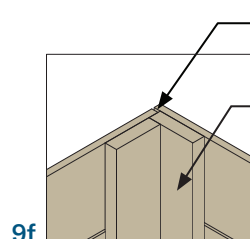

9f INSIDE CORNER ALTERNATE

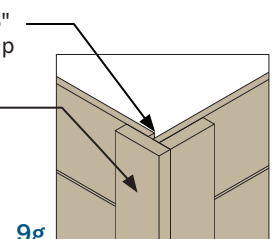

9g OUTSIDE CORNER ALTERNATE

WOOD FRAMED WALL ASSEMBLIES - EXAMPLES

* WRB location in wall assembly may vary depending on climate zone or other factors.

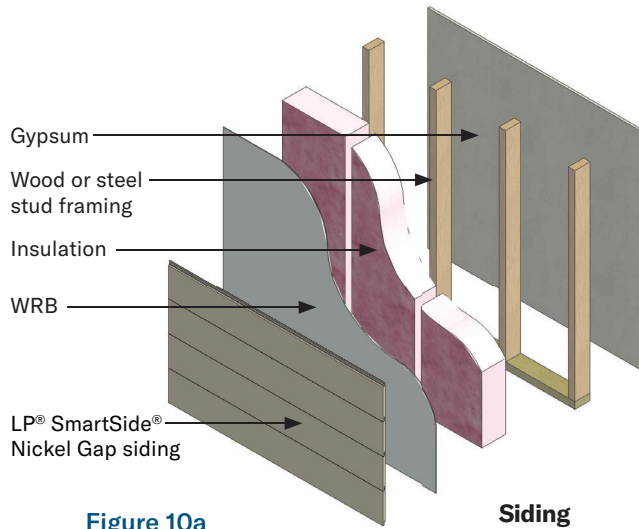

Figure 10a

Siding without Sheathing

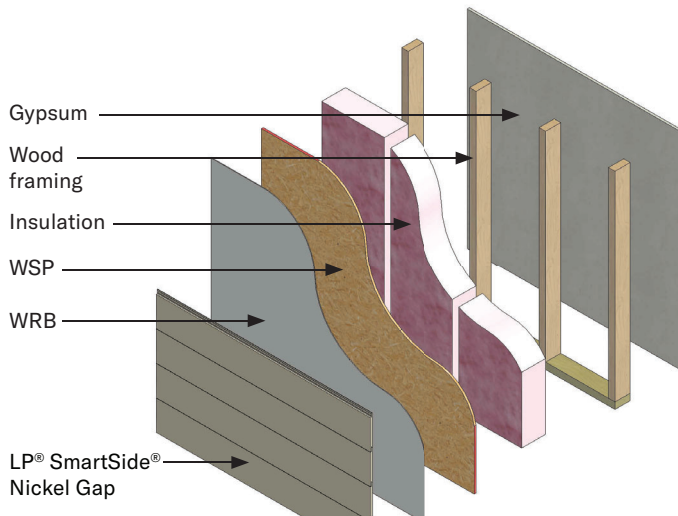

Figure 10b

Siding with WSP Sheathing

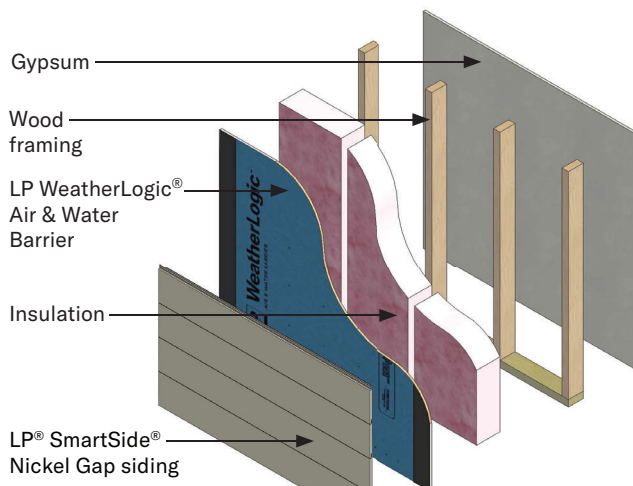

Figure 10c

Siding with LP® WeatherLogic®

LP® SmartSide® Nickel Gap Siding

Application Tips

IMPORTANT Always refer to the complete application instructions for the product you are installing. The application tips provided below are not intended to replace such instructions. Application instructions can be found at LPCorp.com. Failure to follow the full application instructions could cause personal injury or property damage, affect system performance, void any applicable warranty and/or violate applicable building codes.

Exercise safe practices at all times while handling and using this product. Refer to the relevant Safety Data Sheet (SDS) for important information on the safe handling and use of this product. These can be found at LPCorp.com.

- Nickel Gap siding may be attached Direct to Studs or Direct to Wood Structural Panel (WSP) Sheathing:
 - **Direct to Stud** - nails must penetrate structural framing, or combination of WSPs and structural framing min. 1-1/2" (38 mm), some installations may require 2" (51 mm) penetration see PR-N124 or ERS-1301
 - **Direct to WSP Sheathing - ring shank** nails must be long enough to penetrate beyond WSP by 1/4" (6 mm)
- Stud spacing – see application instructions for spacing from 24" (610 mm) o.c.
- See application instructions for alternative nailing options for: Nickel Gap siding installed vertically, SIP assemblies or WSP sheathing, steel studs and ICF assemblies.
- Nail size:
 - **Direct to Stud** – a min. 0.092" shank diameter hot-dip galvanized (ASTM A153, Class D) nail may be used, some installations may require a larger 0.113" shank diameter depending on wind pressure, wind speed and wind exposure limitations in PR-N124. Penetrate studs or combination of studs and WSP a min. 2 inches (51 mm)
 - **Direct to WSP Sheathing** - a min. 0.092" shank diameter hot-dip galvanized (ASTM A153, Class D) **ring shank** nail
- Nail placement – place nail in center of fastener groove.
- Nail head must be snug with flange so it does not interfere with ability for siding stacking or pan flashing to properly integrate
- Nail spacing:
 - **Direct to Stud** – one nail every 16" (406 mm) o.c.
 - **Direct to WSP Sheathing** – nailing pattern varies from 8" (203 mm) o.c. to 24" (610 mm) o.c. depending on the wind pressure, wind speed and wind exposure limitations in PR-N124 or ESR-1301
- Do not overdrive nails – nail head should seat snug to the face of siding or fastener groove, if overdriven - see Application Instructions
- Caulk – use a high-quality, non-hardening, paintable exterior sealant meeting ASTM C920, min. Class 25
- Seal all exposed substrate – sealing can be accomplished by applying a paint or caulk
- Spacing at butt joints and trim – min. 3/16" (5 mm)
- Butt joints – 3 methods:
 1. LP SmartFlash Pan flashing
 2. Field fabricated metal flashing
 3. Non-metal flexible flashing sheet, such as Bear Skin flashing sheets
- Siding clearance at finish grade (ground cover) – min. 6" (152 mm)
- Siding clearance adjacent to surfaces such as porches, patios, or porch columns, etc. – min. 1" (25 mm):
 - May be reduced to 3/8" (10 mm) – see Application Instructions
- Siding must not be in direct contact with CMU, poured concrete, brick, cultured stone, stucco, mortar, etc.
- Drip cap flashing – required above all windows, doors and horizontal trim per manufacturer's instructions:
 - Flashing shall be metal or another durable material that will last for not less than 50 years
 - Provide 3/8" (10 mm) gap above any drip cap flashing, do not caulk gap
- Siding below a windowsills, soffit, horizontal trim or frieze board will require face-nailing - see Application Instructions
- Siding over foam plastic sheathing adds complexity to siding installation – see Application Instructions
- For Limitations of Use – see Application Instructions, Technical Notes, Technical Bulletins and NSA Bulletins